

1		2		3		4		5		6		7		8	
REVISIONS															
ISS	ZONE	DESCRIPTION\PER REQUEST\DATE													

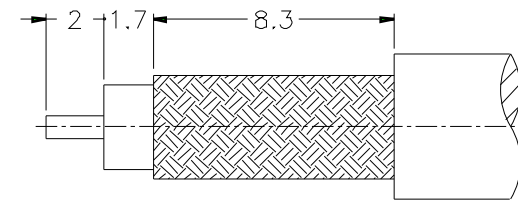

RECOMMENDED
CABLE STRIPPING DIM'S

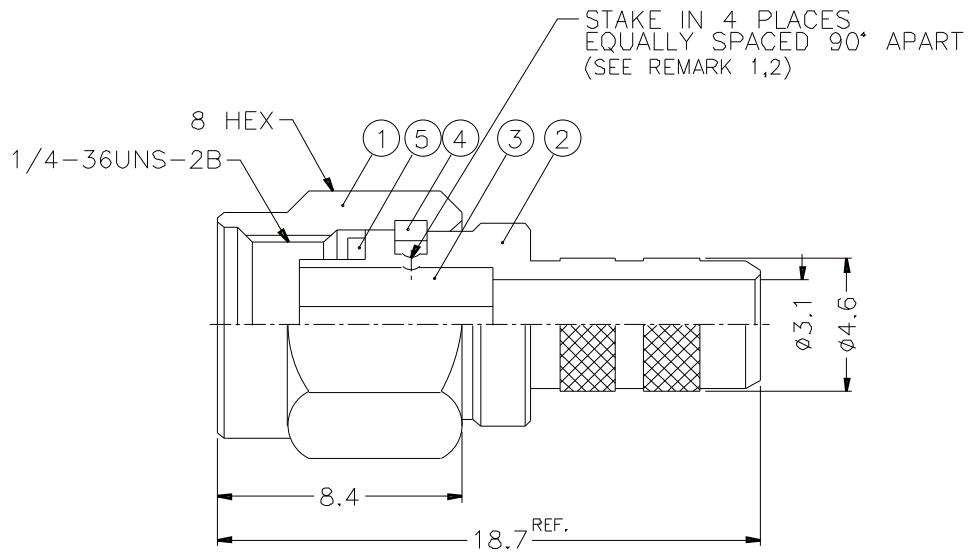
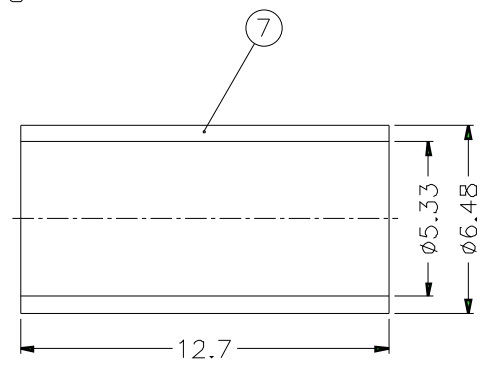
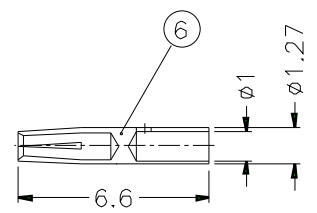

- NOTES: FINISH (PLATING THICKNESS IN MICRO-INCHES)
1. BRASS PER QQ-B-626
 2. GOLD PL. 3 MIN. THICK OVER NICKEL PL. 100 MIN. THICK OVER COPPER STRIKE
 3. BERYLLIUM COPPER PER QQ-C-530
 4. GOLD PL. 50 MIN. THICK OVER NICKEL PL. 100 MIN. THICK OVER COPPER STRIKE
 5. TEFLON MIL-P-19468

- REMARK: 1. NO.3 MUST WITHSTAND A 6 lbs. MIN. PUSHOUT FORCE FROM NO.2 AFTER STAKING OPERATION
2. REMARK1 IS MAINTAINED BY STAMPING THE FOUR POINTS SHOWN ON THE DRAWING WITHOUT PUNCTURING NO.2

1. CRIMPED FERRULE
HEX CRIMP SIZE .213"
2. CONTACT PIN TO SOLDER

7	FERRULE	COPPER	NOTE 2	1	FR-648/533X 127C
6	CONTACT PIN	NOTE 3	NOTE 4	1	SMA7081-3-127/ 1-B
5	GASKET	SILICONE	RED	1	GS-6/43X06
4	RETAINER RING	NOTE 3	NATURAL	1	SMA5000-4-B
3	INSULATOR	NOTE 5	NATURAL	1	RSMA1111A1-3T- 50-B
2	BODY	NOTE 1	NOTE 2	1	RSMA1111A1-2 -46/31
1	SHELL	NOTE 1	NOTE 2	1	SMA5000-1-C
NO.	DESCRIPTION	MATERIAL	FINISH	Q'TY	DRAWING NO.

DIMENSIONS ARE IN MILLIMETERS			PART NO. RSMA1111A1-3GT50G-1-50	
UNLESS OTHERWISE SPECIFIED TOLERANCES			APPROVED	DATE
0.5-6	= ±0.2			10-11-01'
6-30	= ±0.4		CHECKED	DATE
30-120	= ±0.6			10-11-01'
120-315	= ±1		DRAWN	DATE
315-1000	= ±1.6			10-11-01'
1000-2000	= ±2.4			
SCALE	4/1	ISSUE	A	
FILE NO.				

TITLE		SMA REVERSE POLARITY CRIMP PLUG	
DRAWING NO.		KJ-RSMA1111A1-3GT50G-58U-50	
ITEM NO.			